

ELEGIA WHITE PAPER

---



Whether it's high-fidelity loudspeakers, like the latest generation Utopia Evo, or breaching new frontiers, like its grand entrance into the high-end headphones sector, Focal has continued to push its own boundaries over the years. Its ultimate mission? Continuous innovation through a unique approach aimed at constantly exceeding the limits of acoustics.

Elear, Clear and Utopia have made significant breakthroughs, both in terms of the measurable performance of full-range speaker drivers and ensuring an exceptional personal listening experience. To do this, Focal set out to deliver from headphones the deeper stirring of emotions that one experiences when listening to the best high-fidelity loudspeakers. These three models of open-back headphones are writing the first lines in a new adventure for Focal: the continuous search for supreme near-field acoustics.

However, because of their very open mechanical construction, these three models require a relatively quiet listening environment. So what happens when we want to listen to music in potentially noisier settings? How do we make this possible without giving in to all-too-common compromises?

In a bid to create a solution that lets you listen to your favourite songs in noisy environments or, simply, to enjoy an intimate listening experience without disturbing the person next to you, we created the Elegia project. Discover how we achieved this by reading our technical dossier and learn about the history of Elegia, Focal's first closed-back high-end headphones, from the beginnings of the research, through the developmental stages, to the birth of the product by way of a unique industrial tool.



# Positioning of an enclosure and design of the front baffle of Elegia

The stereophonic image is one of the most critical points when it comes to headphones. Indeed, its reproduction is much easier through a pair of speakers, since this exercise is mainly to define the correct spacing between the left and right speakers, determine the listening position and to adjust the orientation of the speakers. Traditionally, the principle of the equilateral triangle is a good place to start.

However, this is much more complex when it comes to approaching this point when designing headphones, as the distance between the right and left speakers is far more critical than the distance of the speakers in relation to the ears.

Also, to promote the best possible stereo image, Focal has developed a single front speaker to position the speakers as far forward as possible from the listening position. The limit here is not to have too much space between the speakers and the ears to ensure the best dynamics and an ideal tonal balance on the entire audio spectrum.

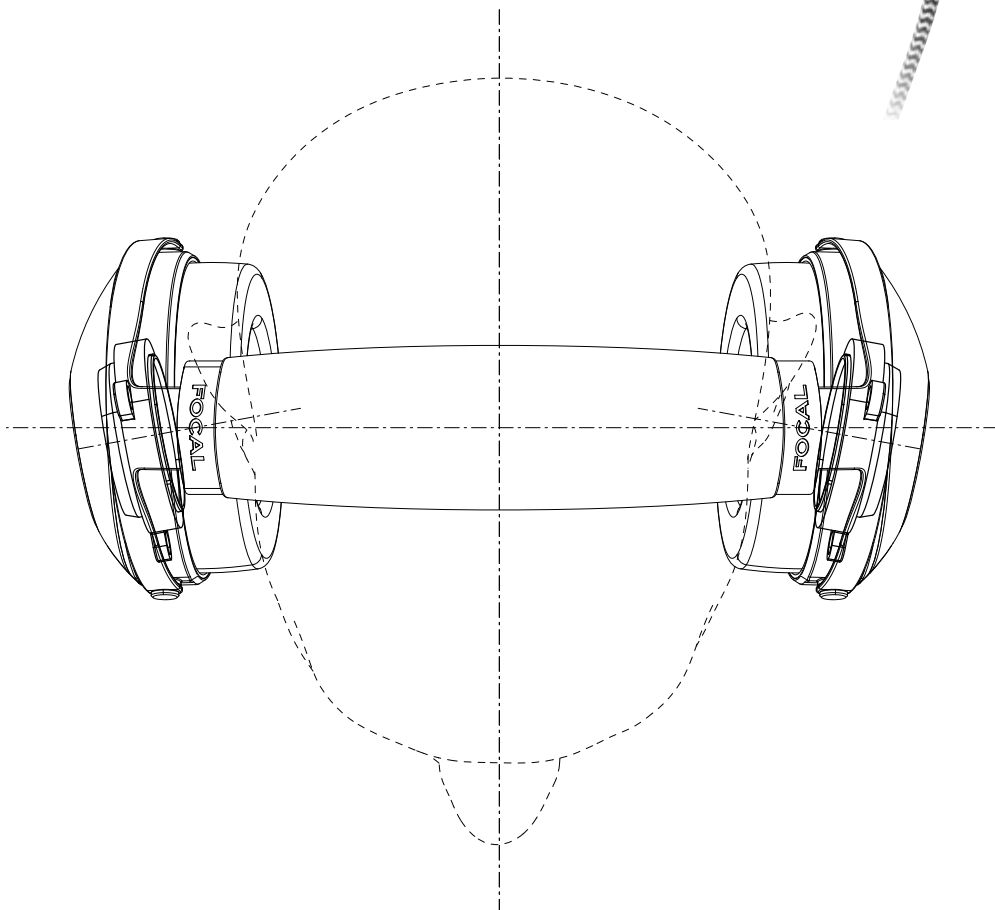

## Speaker driver design

The previous technical file dedicated to Elear and Utopia allowed us to draw parallels between the design of a pair of very high-end loudspeakers integrated into a large and acoustically optimised room, and a pair of headphones, bringing together all of these parameters.

Like any self-respecting music lover, we all want the best high-fidelity system. However, we don't all have the luxury of a large enough and acoustically optimised room. A small listening space forces us to accept a number of compromises. The first of which being the size of the loudspeaker, closely linked to the extent of the bass frequency response. Then, there is its positioning within a limited area, which is always a clever compromise between integration in the living space and acoustic performance.

Do you sacrifice reproduction of the lowest frequencies? Do you limit yourself to listening to music at a volume you really feel is too low due to reasons of room size or your surroundings? These were exactly the compromises we refused to accept as established facts. For Elegia, we needed to go beyond these limits.

The first job was to define a new generation of transducer, which is capable of operating at a low volume level whilst maintaining exceptional dynamics, deliver an extremely extended frequency response and reproduce the subtlest sound details. Thanks to the knowledge acquired through the Utopia EM project, we have made significant progress in simultaneously managing the bass level and its degree of control.



A speaker driver operating in a limited inner volume environment must first and foremost have low compliance. Indeed, the surround on this type of transducer must permit excellent control of the moving part and thereby induce less elongation. The surround plays a dual role.

The first is to provide the largest elongation possible, which lies at the root of the ability to reproduce the dynamic range of the original audio signal. At the same time, it is also designed to control the travel of the moving part to ensure a piston action from its lowest to its highest amplitude. Focal, therefore, decided to choose a dedicated surround, constructed in the same way as the Elear, Clear and Utopia speaker drivers. The material used is the same, but the thickness of the Elegia transducer has changed to 110 microns. The geometry of this new half-roll NBR surround was the subject of an extremely detailed study into how to gain optimum control of the moving part, even at the lowest frequencies and loudest volumes.

At the same time, wanting to reproduce the subtlest sound details required an important research stage on minimising the moving mass, whilst providing more magnetic flux. This allows us to obtain extraordinary traction.

The innovation unveiled in the Elear, Clear and Utopia headphones has been tailored in the tiniest of details to the specific needs of this new speaker driver. The frameless voice coil, exclusive to Focal headphones, provides a significant native weight saving.

The need for more magnetic flux, for increased speaker driver control, led to the design of a brand new copper wire, working inside a very high-performance N50 grade neodymium motor. The magnetic damping curve highlights the significant advantages inherent in this perfectly formed relationship.

First of all, it is interesting to note that the electric damping factor is extremely linear, regardless of the position of the coil in the gap. This translates into excellent stability of the magnetic flux crossing the coil, even at full excursion and incursion. It also shows the perfect control of the moving part, from its smallest to greatest articulation.

The very low QES provides excellent electrical damping, over the entire travel of the moving part. The signal is, therefore, reproduced without additions, losses and any dynamic compression across the entire spectrum.

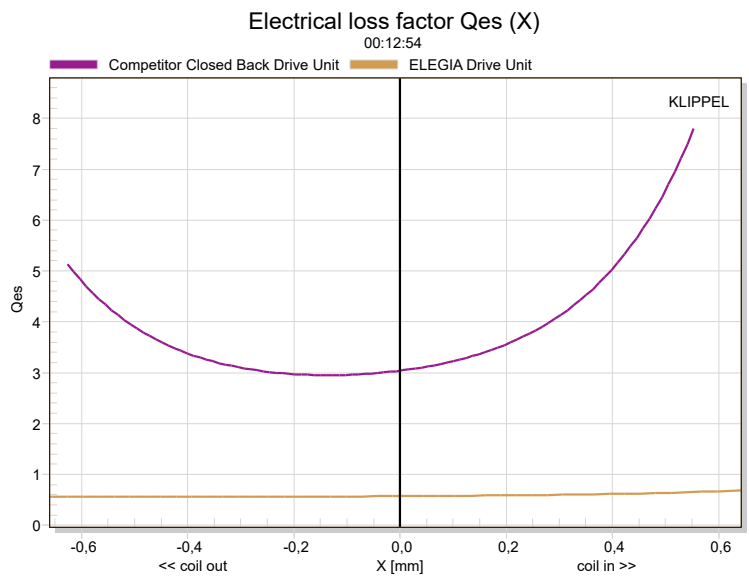

And remember, in the case of a transducer used in a bass-reflex volume, the need for articulation is reduced. Ultimately, this enables the height of the coil to be reduced (from 0.20 inches - 5 mm in the Elear, Clear and Utopia to 0.16 inches - 4 mm in Elegia). This provides a significant advantage in terms of use: giving it even lower impedance (35 Ohms). The significance of this low impedance lies in the source equipment used. Closed-back headphones are usually intended for more on-the-go use than open-back headphones and, therefore, are often associated with a portable audiophile player. Without it, the amplification power available is limited by the physical dimensions of the source. Adding headphones with the lowest possible impedance therefore makes perfect sense and gets the very best from this combination.

The aluminium-magnesium alloy dome used for Elegia uses the same materials and geometry as those developed for the Clear headphones. It offers an ideal combination of lightness, high rigidity and excellent damping. As such, the dome still works by piston-effect and is free from mechanical distortion. The "M"-shape of the dome permits a larger emissive surface area, enabling even greater maximum SPL. At the same time, this choice results in the ideal coil positioning for optimum mechanical coupling.

Aluminium-Magnésium  
alloy dome



In short, the moving part is always under control and has maximum acceleration capacity, key to reproducing subtle sound details. The frequency response curve is also extremely linear by way of the upstream work performed on all the components (dome, surround, coil). Thus, the filtering carried out downstream will be decidedly minimal, favouring a dynamic and highly accurate reproduction of the original audio signal. Developing the transducer in this way provides an extended frequency response of 23 kHz.

The desire not to limit the frequency response in the low-range, even in a small room, led to specific work on the vents. Here, our engineers drew on some 40 years of experience in designing and manufacturing cabinetry and bass-reflex loudspeakers to properly manage the air flows and their interaction with the extent and balance of the frequency response in the bass and midbass.



To this end, the full-range Elegia speaker driver has a built-in vent, designed to manage the balance between the bass and midbass. The second vent, positioned on the back of the ear cup, picks up the rear wave coming from the centre of the motor. The latter is extremely open, preventing any dynamic compression and allowing us to take advantage of the airflow to extend the speaker driver's frequency response by offering it a larger usable volume than just the inner volume environment of the ear cup.



How? Through the vent, which ensures the connection between the centre of the motor and the outer part of the ear cup, located beneath the logo. Once the vent is tuned in terms of length and surface area, the speaker driver's response in the bass-reflex acoustic loudspeaker is extended to the lowest frequencies, while providing remarkable linearity and bass articulation in every respect. This solution also enables excellent decompression, which translates to a listening experience free from the resonances frequently encountered in closed-back headphones.

Ultimately, the sum of these innovations also results in an extremely low distortion level, whilst providing an uncompromising range of frequency response.

## Ear cup design

Loading a speaker driver into an inner space makes it extremely sensitive to its environment. Research was undertaken to determine the ideal volume for optimised decompression and damping, with regard to certain parameters of the loudspeaker (emissive surface, elongation and compliance). Alongside this was the question of back wave dissipation. Here, the lowest frequencies benefit from a vent designed to provide decompression, as is the case in studios with small control rooms. Located in the logo, the progressive design of this vent enables dissipation of the lowest frequencies, without disruption, via a specific geometry that avoids any phenomena of dynamic compression and turbulence inside it.



As for the higher frequencies, these are absorbed through an EVA foam pad inside the ear cup, behind the speaker driver. Finally, acoustic diffusers fitted inside the ear cup fulfil two objectives. The primary aim of the diffusers is to break-up the standing waves and spread the residual energy homogeneously through the overall space. The main objective here being at all costs to prevent the energy emitted by the back wave from returning to the speaker driver cone and thus turning into an additional unwanted sound signal. The diffusers are also an additional material, making the “cabinetry” even more rigid and, as a result, inert. As such, only the speaker driver generates the sound reproduction, without interfering, adding or removing information from the sound signal.



## The earpads or the acoustic treatment of the room

Starting from the principle that the earpads are the equivalent to an acoustically optimised listening room, this component is extremely critical in terms of design and its impact is extremely high on acoustic performance.

The research undertaken for Elear, Clear and Utopia had already hugely enriched the knowledge of the R&D engineers. For Elegia, the problem lays in the ability to successfully soundproof against external noise, whilst favouring the dynamics and extent of the frequency response in the bass. We also wanted to eradicate the resonance all-too-frequently encountered in the closed-back headphones sector. Just like a small listening room, closed-back headphones have high acoustic impedance. It is, therefore, necessary to design relatively closed earpads to avoid any acoustic short-circuit, otherwise there will be significant losses in the lower frequencies.

The Elegia earpad provides excellent soundproofing against the external environment, whilst benefiting from an excellent ratio between damping and diffusion, all within a tiny listening space. Although the microfibre earpads are the same as those on the Clear headphones, Elegia's are unperforated, which provides better soundproofing. This generates extreme performance with the most direct radiation possible from the speaker driver to the ear, without the usual artifices (foam around the transducer, etc.), for optimal dynamics and sound whose naturalness is noticeable from the very first seconds of listening.



Unperforated earpad

# How are these innovations transferred in terms of industrial tools and processes?

---

One of the key components of Focal's DNA is the complete mastery of the process, from development to industrialisation. A team of production method engineers was therefore tasked with transferring these innovations to an industrial tool.

The extreme light weight of the moving part composing the Elegia full-range speaker drivers means it is necessary to strictly control the quantities of glue used on the surround-dome/dome-coil connections. A new robot was developed to implement this priority, as well as bringing exceptional repeatability and stability to the production process.

The 5 stages in the production process for the Elegia full-range speaker drivers are:

- assembly of the bowl, surround and voice coil
- assembly of the magnetic circuit
- measurement of each speaker driver followed by pairing
- assembly of the speaker drivers inside the headphones
- measurement of the headphones then final quality control.

At the end of this process, all the speaker drivers provide almost identical frequency response curves, as they are set within a window of +/- 0.5 dB.







Focal-JMlab\* - BP 374 - 108, rue de l'Avenir - 42353 La Talaudière cedex - France - [www.focal.com](http://www.focal.com)  
Tel. (+33) 04 77 43 57 00 - Fax (+33) 04 77 43 57 04 - SCAA-180903/1 - CODO1590